

# Assembly, Operating & Maintenance Instructions

Remove all items from the carton. Verify all pieces before assembly.

## BURO EVEREST CHAIR - WITH CHROME BASE - LEATHER / MESH SEATED

### STEP 1.

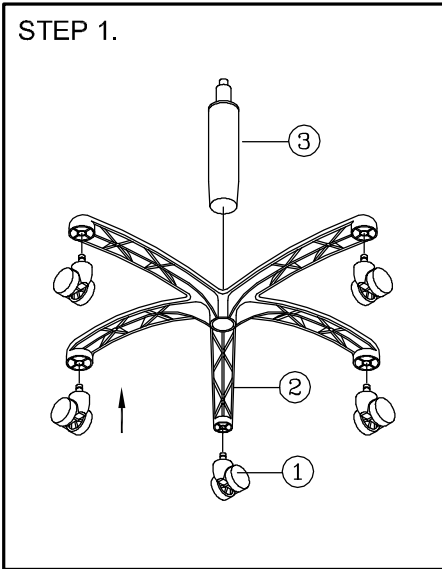

### STEP 2.

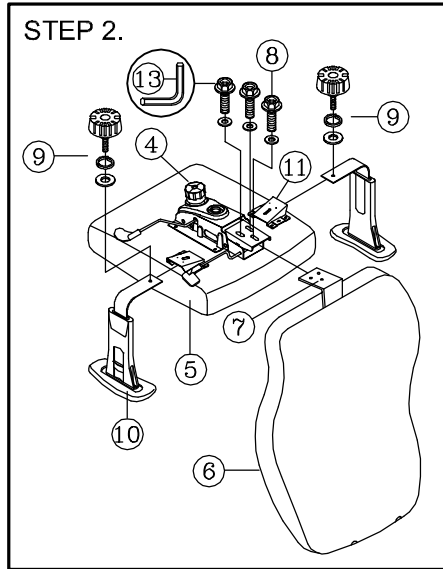

### PART LIST

KEY	QTY	DESCRIPTION
1	5	Castors
2	1	Base
3	1	Gas Lift
4	1	Mechanism
5	1	Seat
6	1	Backrest
7	1	Backrest Post
8	3	Mechanism Bracket
9	2	Screw + Washer
10	2	Arm Width Adjustment
11	2	Knob + Washers
12	1	Armrests
13	1	Arm Bracket
		Headrest Pad
		M5 Size Allen Wrench

### STEP 3.

**ATTENTION :** Put headrest on top of backrest after assembling chair. It provides more comfort while sitting and it can be remove anytime.



### CARE & MAINTENANCE

#### GENERAL CARE

To maintain the appearance of non-upholstered parts wipe the surface with a clean cloth dampened with a mild detergent solution.  
Do not remove any parts for separate cleaning.  
Do not saturate the fabric or interior with water or other cleaning liquids.  
Do not shampoo clean.  
Do not clean with hot water extraction machine.  
Do not clean with onsite drycleaning machine.  
Protect from direct sunlight, heat and weather.

#### LEATHER UPHOLSTERY CARE

Wipe with a clean cloth dampened with a mild upholstery detergent solution.  
A soft bristle brush may be used to remove ingrained soil.  
Use only leather care products suitable for top coated leather and strictly in accordance with the manufacturer's Instructions.  
Spot clean as above.  
Treat spills and stains as soon as possible.  
Persistent stains may require treatment by a professional cleaner.  
Allow to dry thoroughly before reuse.

### FOAM & UPHOLSTERY SPECS\*

#### FOAM

Flame Resistance: Ca117 Section A Part I & Section D Part II

#### UPHOLSTERY

Flame Resistance: Ca117 Section E Class I

\*This applies only to standard Buro stock. Any customer specified upholstery may not meet these specifications.

### MECHANISM OPERATING INSTRUCTIONS

**IMPORTANT NOTE:** Do not operate the mechanism levers unless properly seated in the chair.

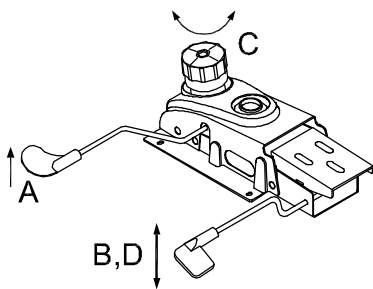

- (A) **SEAT HEIGHT ADJUSTMENT :**  
Pull lever up and downward . Release lever when desired position is reached.
- (B) **BACK TILT ADJUSTMENT :**  
Turn the lever up, move backrest to tilt. To lock in position , turn lever down.
- (C) **TILT TENSION ADJUSTMENT KNOB :**  
Rotate knob clockwise / counterclockwise to adjust tilt tension based on body weight.
- (D) **TILT LOCK**  
Lock and release switch of synchronized tilt with 3-position stop.

### PREVENTATIVE MAINTENANCE & WARNING!

- Use this product only for seating one person at a time.
- Do not use this chair as a step stool / ladder.
- Do not sit on any part of the chair except the seat.
- Do not use this chair on uneven floor surfaces.
- Do not interfere with the operating of the gas lift.
- Do not use chair unless all bolts, screws and knobs are tight. At least every six months check all bolts, screws and knobs to ensure they are tight.

- If any parts are missing, broken, damaged or worn do not use the product until repairs are made using factory authorised parts.
- Dispose of packaging properly.
- Plastic bag is not a toy.
- Do not use plastic bag as a head covering as it may cause suffocation.
- Failure to follow these warnings could result in serious injury.