

Assembly & Maintenance Instructions

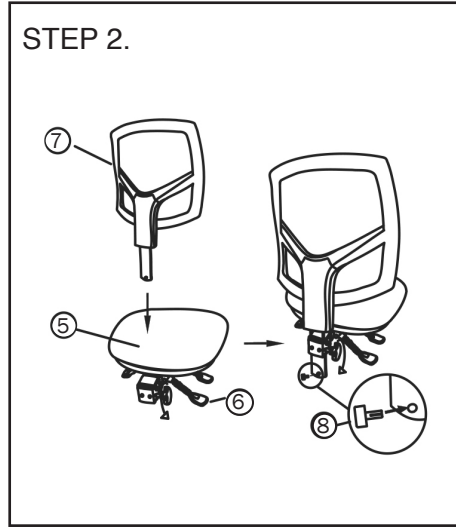

MONDO JAVA MESH BACK 3 LEVER CHAIR

Remove all items from the carton. Verify all pieces before assembly.

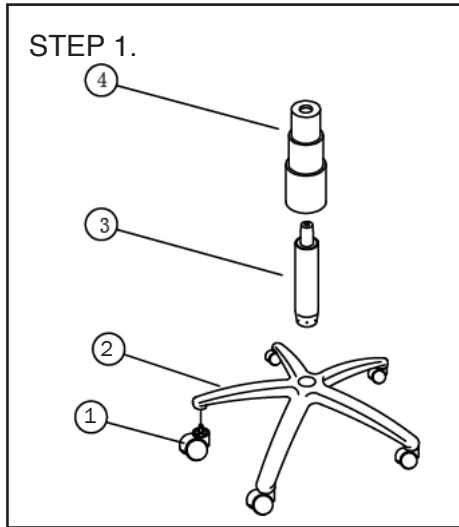

PART LIST

KEY	QTY	DESCRIPTION
1	5	Castors
2	1	Chair Base
3	1	Gas Lift
4	1	Gas Lift bellows
5	1	Seat
6	1	Seat Mechanism
7	1	Back
8	1	Plastic Stopper
9*	4	Long Arm Screws
10*	2	Short Arm Screws
11*	1	Allen Wrench
12*	2	Arms

* Optional Arm hardware only for Java chairs purchased with arms.

CARE & MAINTENANCE

GENERAL CARE

- To maintain the appearance of non-upholstered parts wipe the surface with a clean cloth dampened with a mild detergent solution
- Do not remove any parts for separate cleaning
- Do not saturate the fabric or interior with water or other cleaning liquids
- Do not shampoo clean
- Do not clean with hot water extraction machine
- Do not clean with onsite drycleaning machine
- Protect from direct sunlight, heat and weather.

UPHOLSTERY CARE FOR FABRIC

- Wipe with a clean cloth dampened with a mild upholstery detergent solution
- A soft bristle brush may be used to remove ingrained soil
- Spot clean as above. Treat spills and stains as soon as possible
- Persistent stains may require treatment by a professional cleaner
- May be cleaned with dry powder cleaners
- Allow to dry thoroughly before reuse.

MECHANISM OPERATING INSTRUCTIONS

NOTE: Do not operate the mechanism levers unless properly seated in the chair.

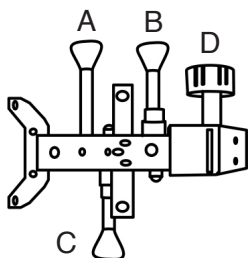

- A. Seat height adjustment
- B. Back angle adjustment
- C. Seat angle adjustment
- D. Back height adjustment

ARMS:

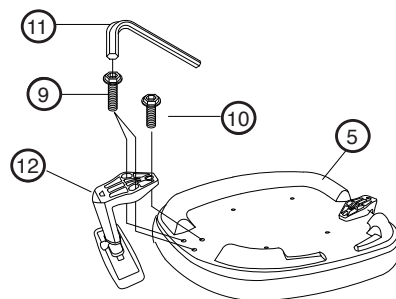

* Arm assembly instructions are for Java Mid Back chairs purchased with arms only.

UPHOLSTERY & FOAM SPECS*

FOAM

Flame Resistant: Ca117 Section A Part I & Section D Part II

UPHOLSTERY: FABRIC

Flame Resistance: Ca117 Section E Class I

* This applies only to standard Mondo Stock. Any customer selected upholstery may not meet these specifications.

PREVENTATIVE MAINTENANCE & WARNING!

- Do not use this chair as a step stool/ladder.
- Do not sit on any part of the chair except the seat.
- Do not use this chair on uneven floor surfaces.
- Do not open, heat up or interfere with the operation of the gas lift
- Do not use chair unless all bolts, screws and knobs are tight. At least every three months check all bolts, screws and knobs to ensure they are tight.
- If any parts are missing, broken, damaged or worn do not use the product until repairs are made using factory authorised parts.
- Dispose of packaging properly.
- Plastic bags used for packaging are not toys.
- Do not use plastic bag as a head covering as it may cause suffocation.
- Failure to follow these warnings could result in serious injury.
- Use this product only for seating one person at a time.
- Indicative Weight Usage:
- Indicative daily sitting hours: